

VACUUM BREAKERS

CVB-200

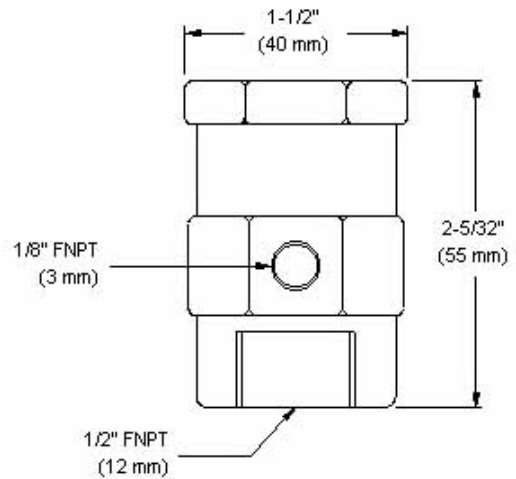

Model CVB-200



APPLICATIONS

- Heat Exchangers
- Storage Heaters
- Air Coils
- Steam Boilers
- Jacketed Kettles
- Zoned Steam Mains
- Zoned Radiators With Gravity Returns

RATINGS

	CVB-200	CVB-200SS
PMA: (maximum allowable pressure)	230 psi	580 psi
PMO: (maximum operating pressure)	200 psi	200 psi
TMO: (maximum operating temperature)	400°F	500°F

MATERIALS

Part	CVB-200	CVB-200SS
Body	Brass	304 Stainless Steel
Cover	Brass	304 Stainless Steel
Gasket	304 Stainless Steel	304 Stainless Steel
Ball	304 Stainless Steel	304 Stainless Steel
Seat	304 Stainless Steel	304 Stainless Steel

INSTALLATION

Installation should be only in the vertical upright position.

Vacuum breakers should be placed at the highest practical points.

AIR CAPACITY (DISCHARGE TO ATMOSPHERE) IN SCFM

1" Hg	2" Hg	3" Hg	4" Hg	5" Hg	6" Hg	7" Hg	8" Hg	10" Hg	12" Hg	15" Hg
1.5	2.0	2.5	2.75	2.95	3.15	3.5	3.8	4.2	4.6	5.0

C_v (Flow Coefficient) = 0.6
 ΔP required to open valve = 3/16" Hg

Colton has a policy of continuous product research and improvement and reserves the right to change design and specifications without notice

